

This Space For Architect/Engineer Approval
 Job Name _____ Date _____
 Model Specified _____ Quantity _____
 Customer/Wholesaler _____
 Contractor _____
 Architect/Engineer _____

EPA ct2005 COMPLIANT

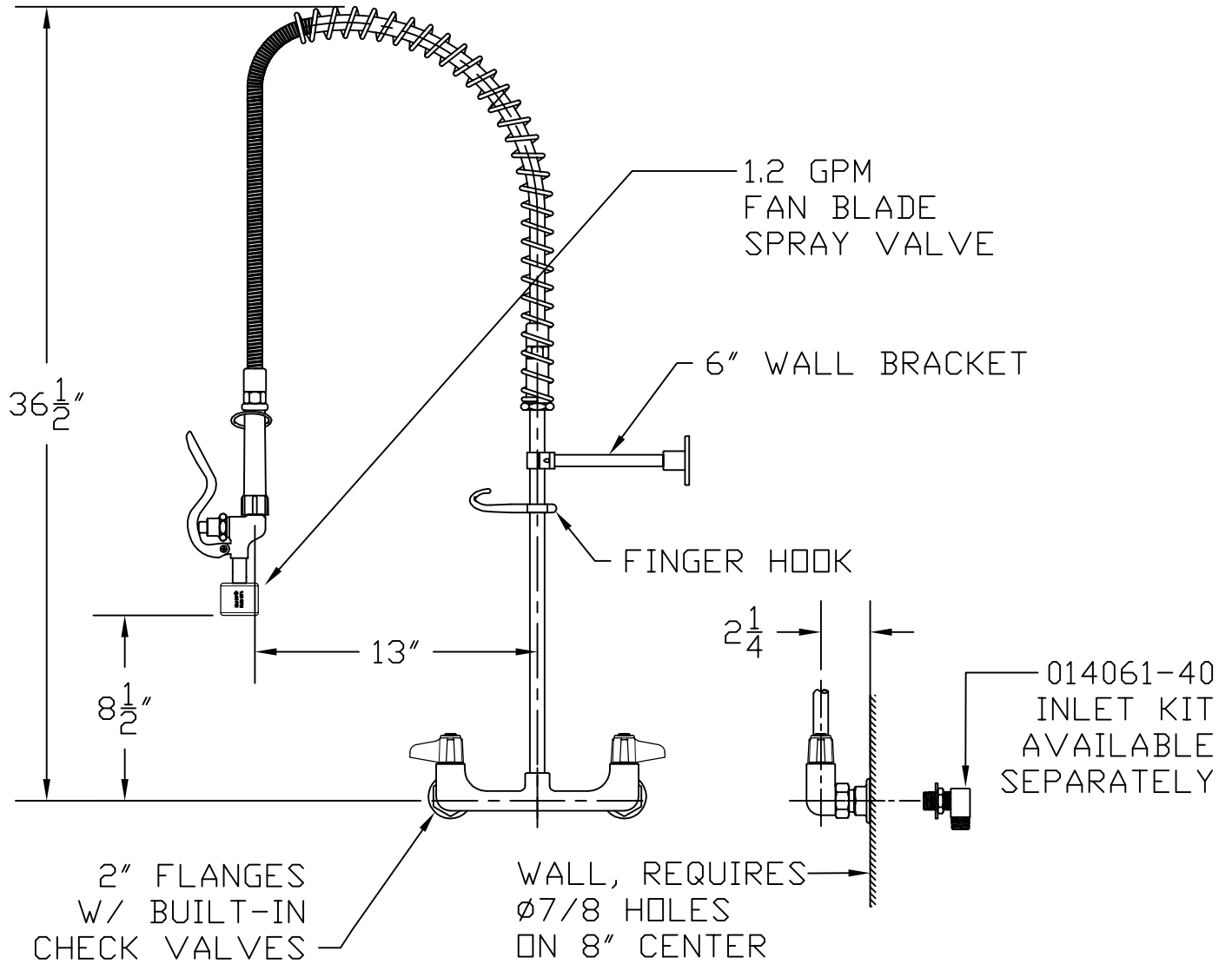

DIMENSIONS ARE APPROXIMATE

MODEL NUMBER 5PR-8W00-C	DATE 6/12/06	SCALE 1:8	DRAWN JRM	CHECKED WJS	APPROVED JHB
----------------------------	-----------------	--------------	--------------	----------------	-----------------

DESCRIPTION
8" WALL MOUNT LOW FLOW PRU



equip Foodservice Accessories
 P.O. BOX 1088, 2 SADDLEBACK COVE
 TRAVELERS REST, SOUTH CAROLINA 29690
 PHONE: 800.891.4808 FAX: 800.868.0084