

INCHES

1

2

3

3/4-27 LAMINAR  
OUTLET

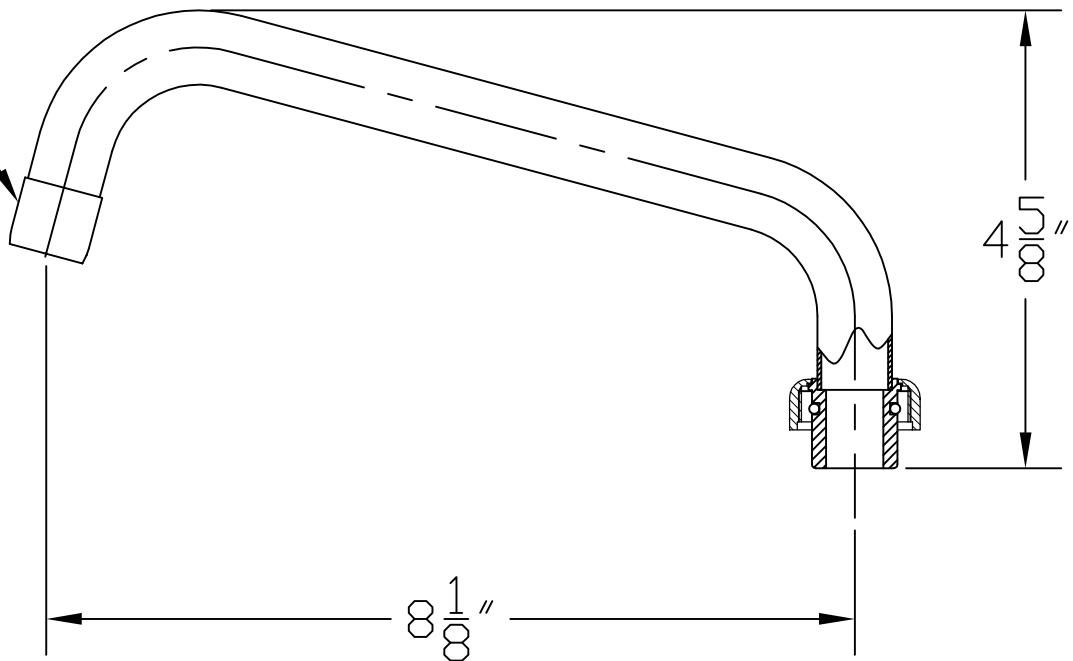

MODEL NUMBER

**5SP-08**

DATE

**11/09/04**

SCALE

**1:2**

DRAWING SIZE

**A**

DRAWN

**MVW 10/24/02**

CHECKED

**WJS**

APPROVED

**MVW**



DESCRIPTION

**8" SWING NOZZLE, EQUIP**

equip Foodservice Accessories



REG. #A2601  
ISO #9001

P.O. BOX 1088, 2 SADDLEBACK COVE  
TRAVELERS REST, SOUTH CAROLINA 29690  
PHONE: 800.891.4808 FAX: 800.868.0084