



T&S BRASS AND BRONZE WORKS, INC.

2 SADDLEBACK COVE / P.O. BOX 1088 / TRAVELERS REST, SC 29690

PHONE 800-476-4103

FAX 803-834-3518



REG.#A2601
ISO #9002

Model No.

B-0668-POL

Item No.:

Job Name:

Architect/Engineer Approval:

Notes:



ADA COMPLIANT

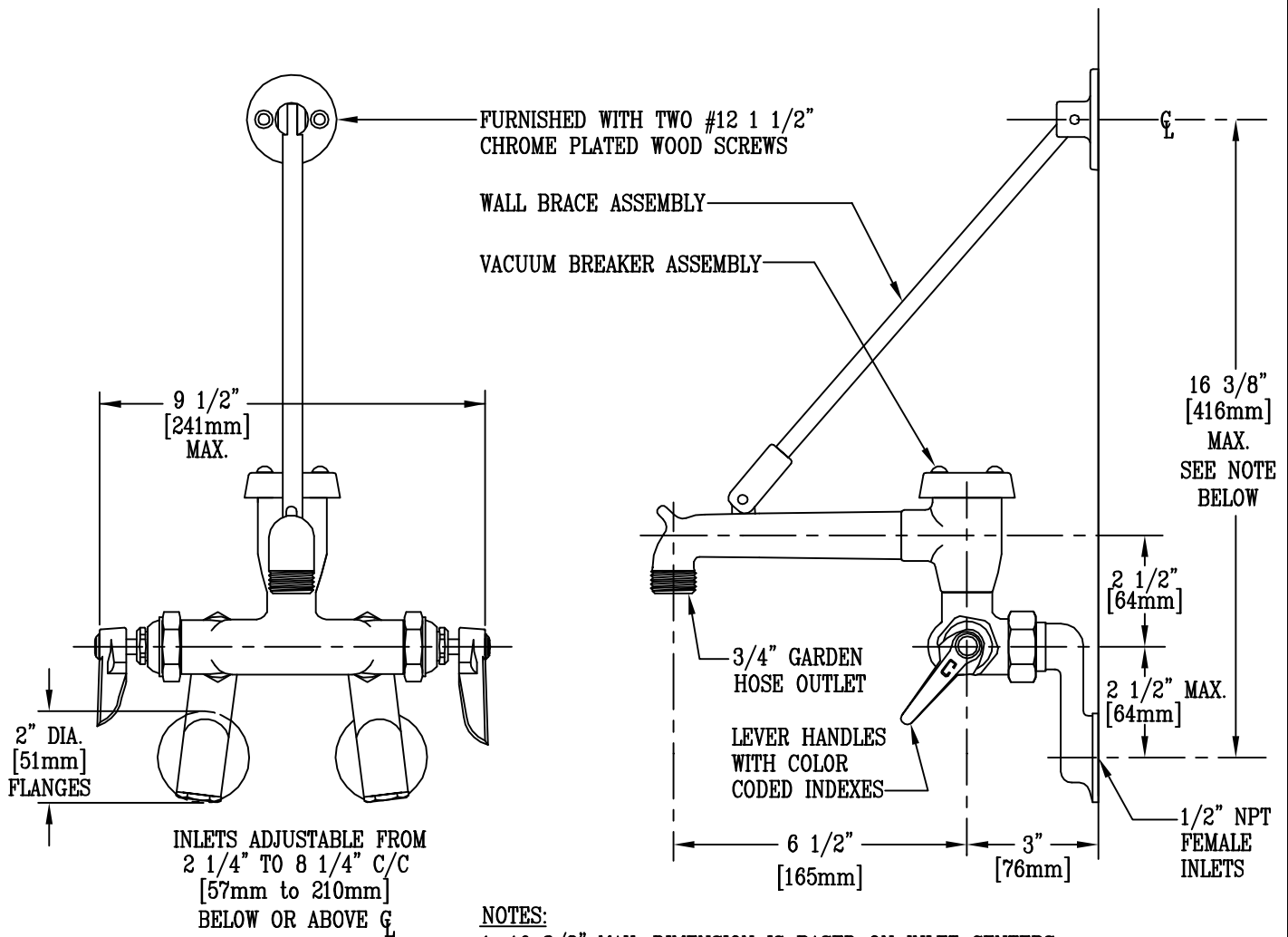

Product Description:
SERVICE SINK FAUCET WITH POLISHED CHROME FINISH,
VACUUM BREAKER, LEVER HANDLES, WALL BRACE,
ADJUSTABLE INLETS, & 3/4" GARDEN HOSE OUTLET

Drawn:

WJS

Approved

CA

Checked

MW

Scale:

3" = 1'

Date:

11/22/95